

# Site Control - Fabric Structure



# Site Control - Air Handling Units



# Site Control – Erosion & Sedimentation

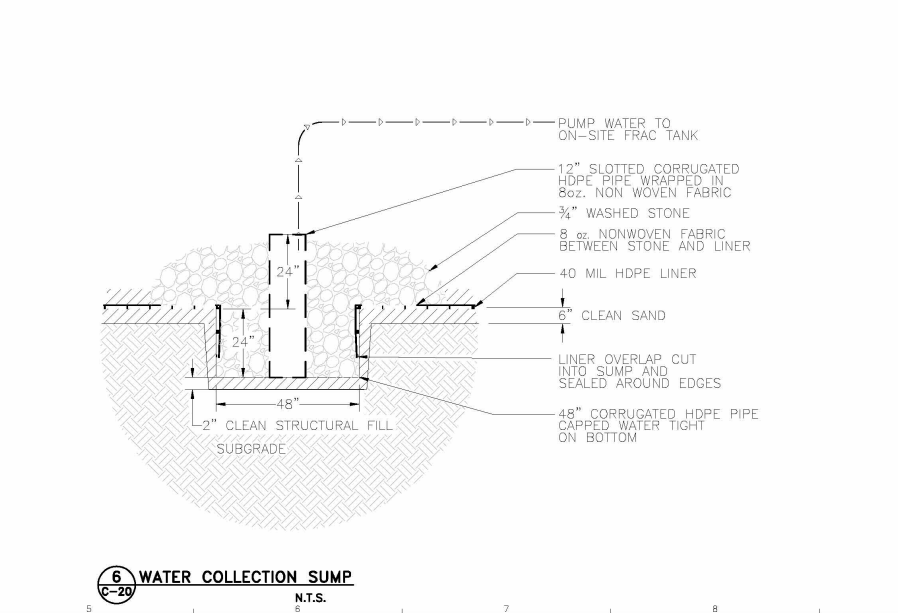
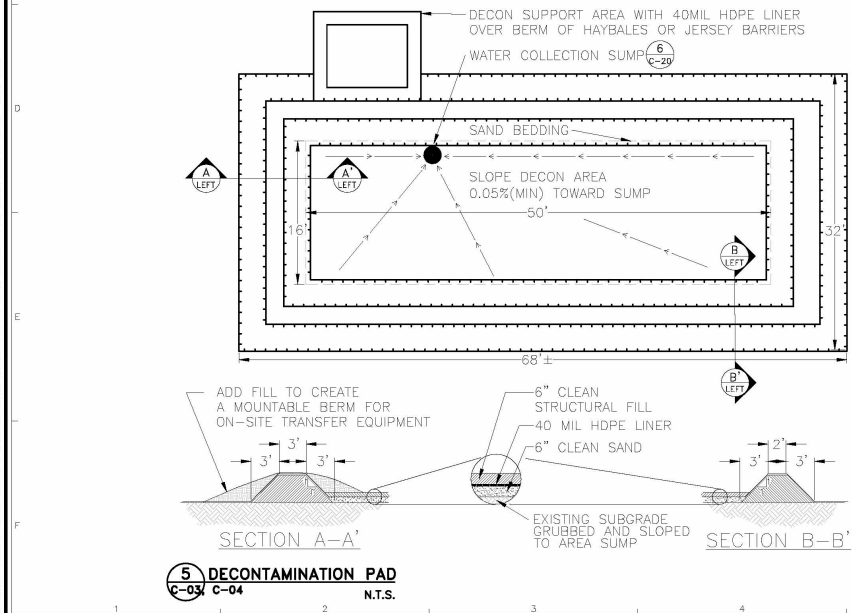
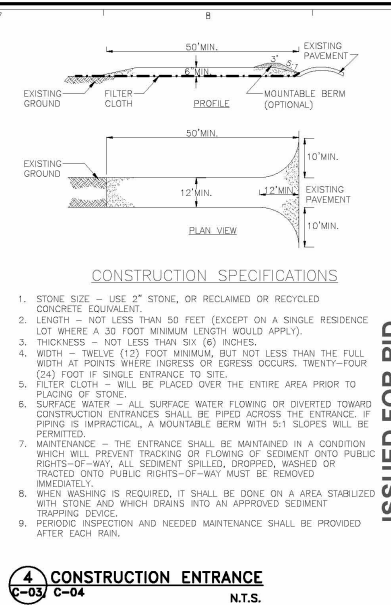
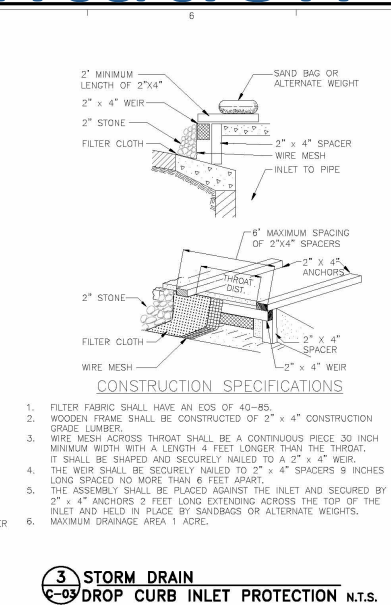
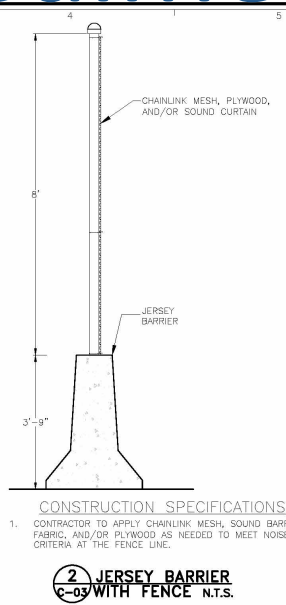
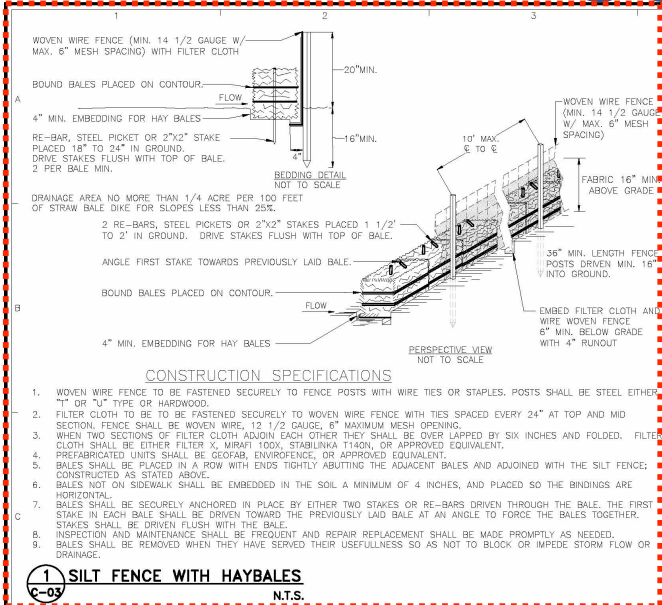

ISSUED FOR BID	
1	ISSUED FOR BID
2	FOR PERMIT
3	FOR PERMIT
4	FOR PERMIT
5	FOR PERMIT
6	FOR PERMIT
7	FOR PERMIT
8	FOR PERMIT
9	FOR PERMIT
10	FOR PERMIT
11	FOR PERMIT
12	FOR PERMIT
13	FOR PERMIT
14	FOR PERMIT
15	FOR PERMIT
16	FOR PERMIT
17	FOR PERMIT
18	FOR PERMIT
19	FOR PERMIT
20	FOR PERMIT
21	FOR PERMIT
22	FOR PERMIT
23	FOR PERMIT
24	FOR PERMIT
25	FOR PERMIT
26	FOR PERMIT
27	FOR PERMIT
28	FOR PERMIT
29	FOR PERMIT
30	FOR PERMIT
31	FOR PERMIT
32	FOR PERMIT
33	FOR PERMIT
34	FOR PERMIT
35	FOR PERMIT
36	FOR PERMIT
37	FOR PERMIT
38	FOR PERMIT
39	FOR PERMIT
40	FOR PERMIT
41	FOR PERMIT
42	FOR PERMIT
43	FOR PERMIT
44	FOR PERMIT
45	FOR PERMIT
46	FOR PERMIT
47	FOR PERMIT
48	FOR PERMIT
49	FOR PERMIT
50	FOR PERMIT
51	FOR PERMIT
52	FOR PERMIT
53	FOR PERMIT
54	FOR PERMIT
55	FOR PERMIT
56	FOR PERMIT
57	FOR PERMIT
58	FOR PERMIT
59	FOR PERMIT
60	FOR PERMIT
61	FOR PERMIT
62	FOR PERMIT
63	FOR PERMIT
64	FOR PERMIT
65	FOR PERMIT
66	FOR PERMIT
67	FOR PERMIT
68	FOR PERMIT
69	FOR PERMIT
70	FOR PERMIT
71	FOR PERMIT
72	FOR PERMIT
73	FOR PERMIT
74	FOR PERMIT
75	FOR PERMIT
76	FOR PERMIT
77	FOR PERMIT
78	FOR PERMIT
79	FOR PERMIT
80	FOR PERMIT
81	FOR PERMIT
82	FOR PERMIT
83	FOR PERMIT
84	FOR PERMIT
85	FOR PERMIT
86	FOR PERMIT
87	FOR PERMIT
88	FOR PERMIT
89	FOR PERMIT
90	FOR PERMIT
91	FOR PERMIT
92	FOR PERMIT
93	FOR PERMIT
94	FOR PERMIT
95	FOR PERMIT
96	FOR PERMIT
97	FOR PERMIT
98	FOR PERMIT
99	FOR PERMIT
100	FOR PERMIT
<b>AECOM</b> <small>AECOM CONSULTANTS INC. 100 WATER STREET, SUITE 2000, NEWTON, MASSACHUSETTS 02459-1000</small>	
<b>NATIONAL GRID FORMER CLIFTON MANUFACTURED GAS PLANT</b>	
<b>SITE PREPARATION AND EROSION CONTROL DETAILS</b>	
DRAWING NUMBER: <b>C-20</b>	DATE: 07/08/11
SHEET NUMBER: <b>1 OF 2</b>	PROJECT NO.: <b>60137363-420</b>
REVISION:	REVISION:

# Site Control – Fence & Noise Control

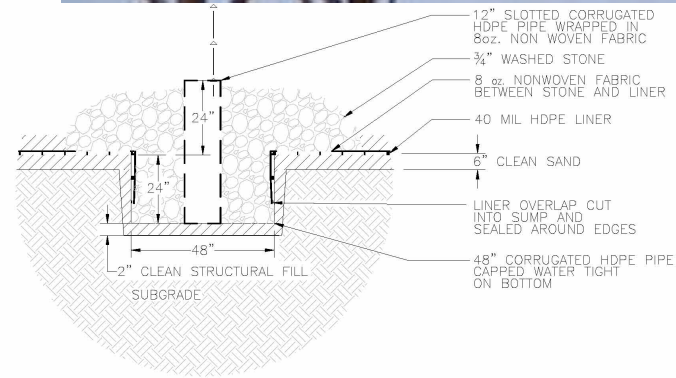
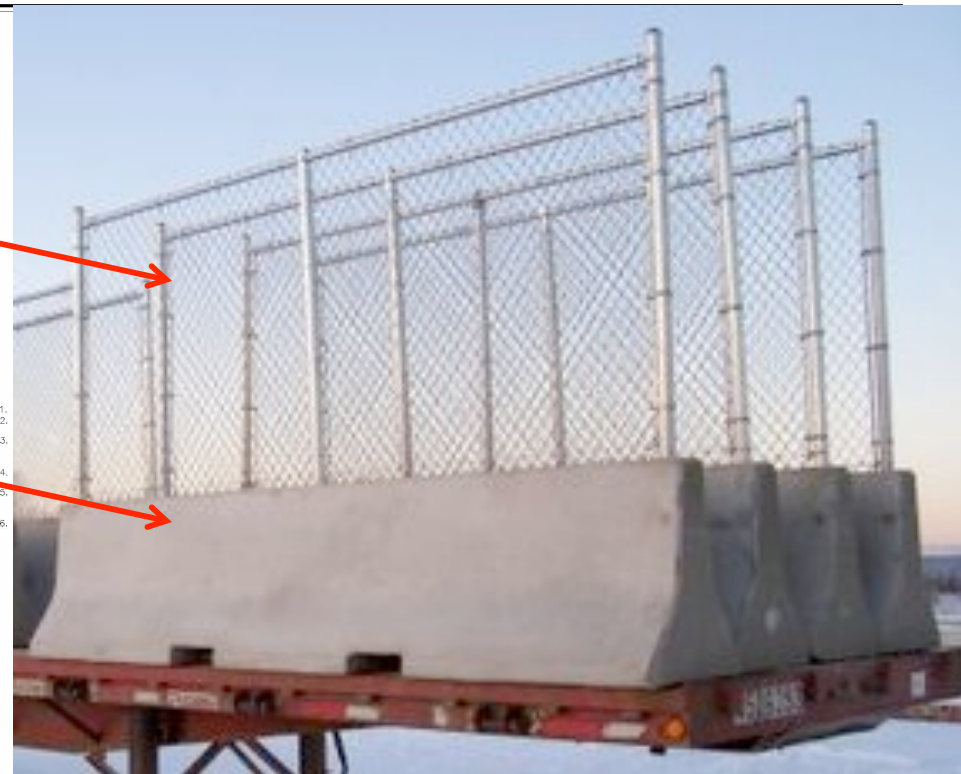
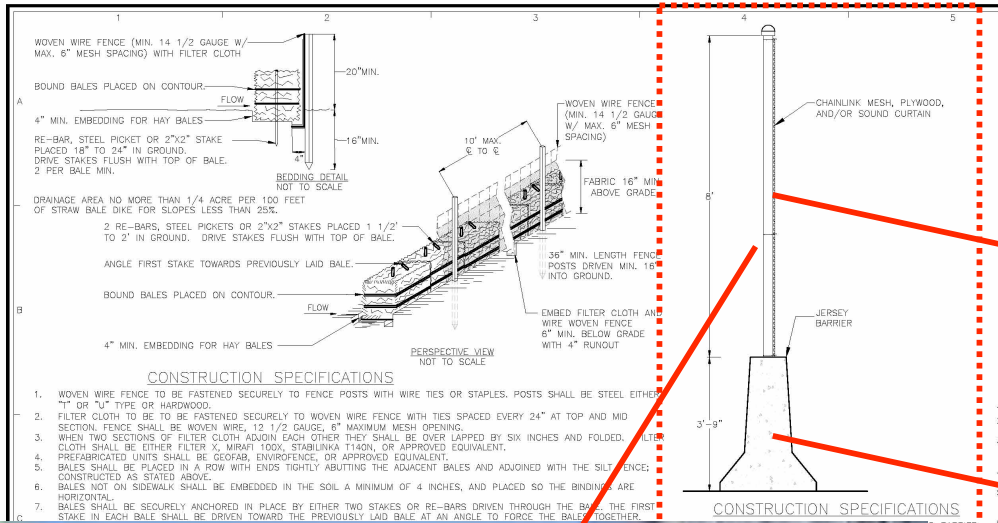

**6 WATER COLLECTION SUMP**  
N.T.S.

<b>SITE PREPARATION AND EROSION CONTROL DETAILS</b>	NATIONAL FORMER CI MANUFACTURED	PROJ. NO.: 60137363-42C
	DRAWING NUMBER: <b>C-20</b>	SHEET NUMBER: 1 OF 2

# Site Control – Storm Drains

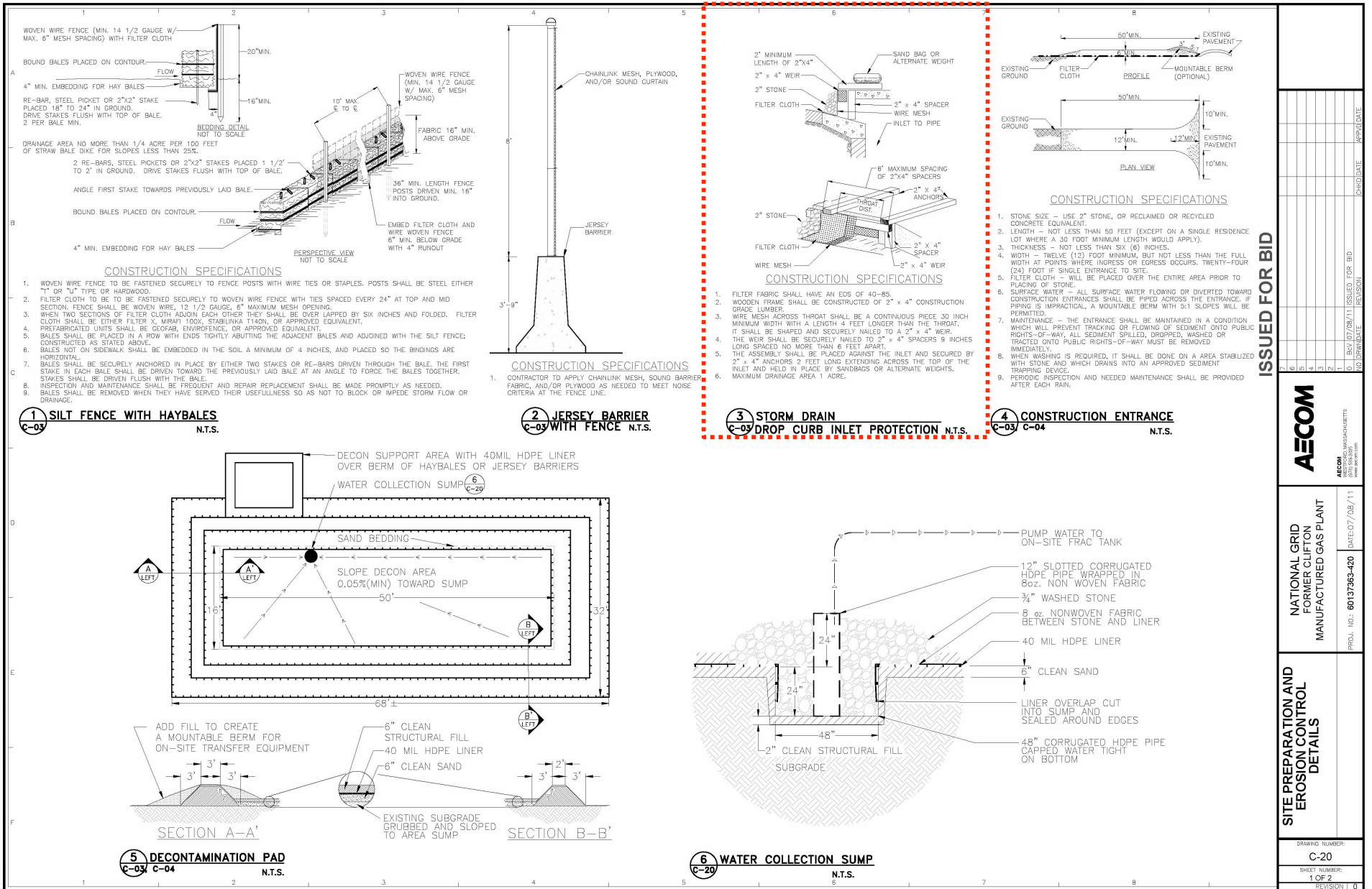

ISSUED FOR BID

<p><b>AECOM</b></p> <p><small>AECOM INC. A REG. PROFESSIONAL ENGINEERING FIRM 1000 RIVER STREET SUNNYVALE, CA 94093 (415) 961-8500 www.aecom.com</small></p>	
<p><b>NATIONAL GRID FORMER CLIFTON MANUFACTURED GAS PLANT</b></p>	
<p><b>SITE PREPARATION AND EROSION CONTROL DETAILS</b></p>	
<p>PROJ. NO.: 60137363-420</p>	<p>DATE: 07/08/11</p>
<p>DRAWING NUMBER: <b>C-20</b></p>	
<p>SHEET NUMBER: 1 OF 2</p>	
<p>REVISION: (0)</p>	

# Site Control – Truck Entrance & Exit

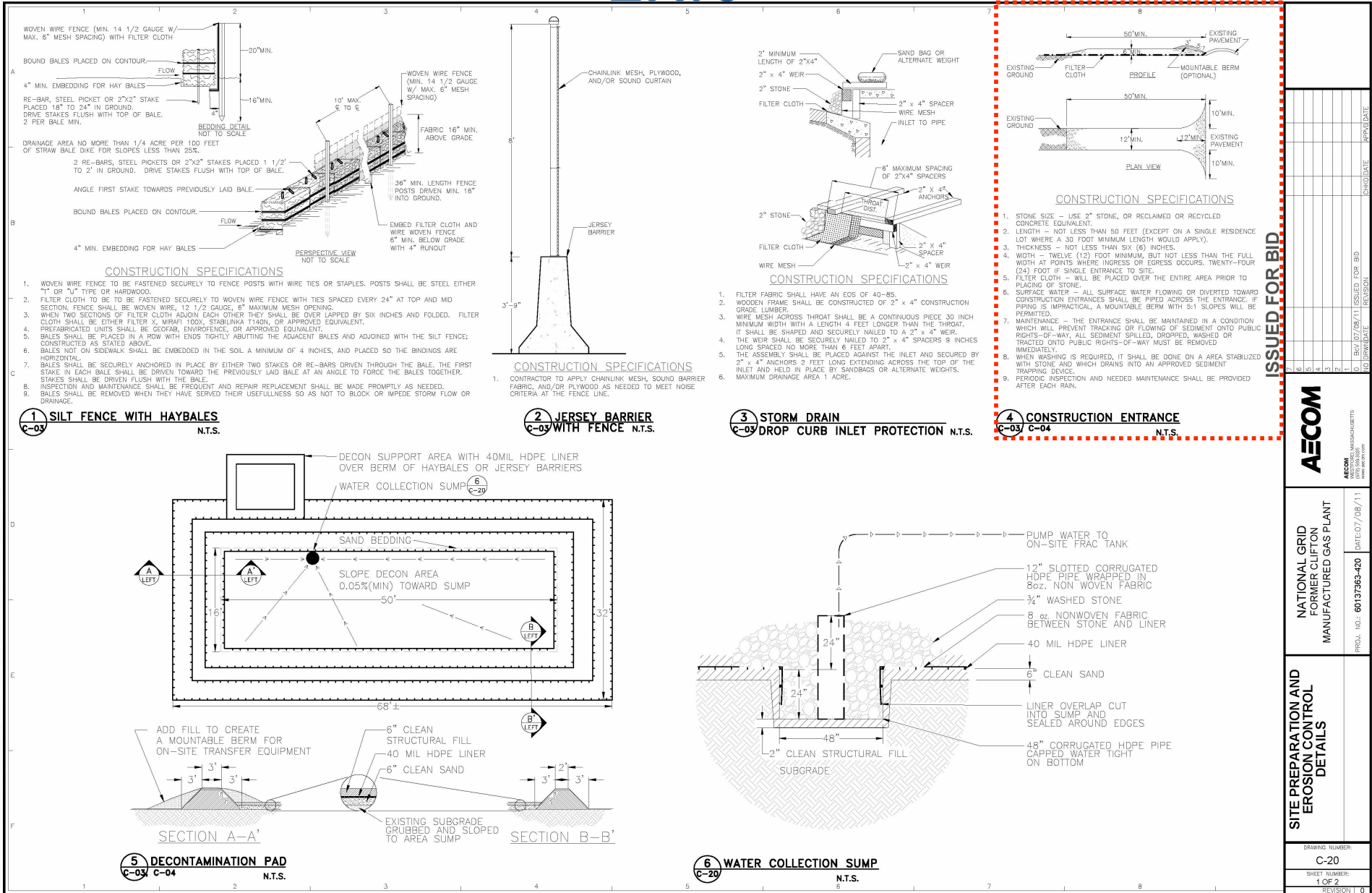

ISSUED FOR BID

NO.	REV.	DATE	DESCRIPTION	APPROVED

**AECOM**  
NATIONAL GRID FORMER CLIFTON MANUFACTURED GAS PLANT

DATE: 07/08/11  
PROJECT NO.: 60137363-420

**SITE PREPARATION AND EROSION CONTROL DETAILS**

DRAWING NUMBER: C-20  
SHEET NUMBER: 1 OF 2  
REVISION: 0

# Site Control – Truck Cleaning

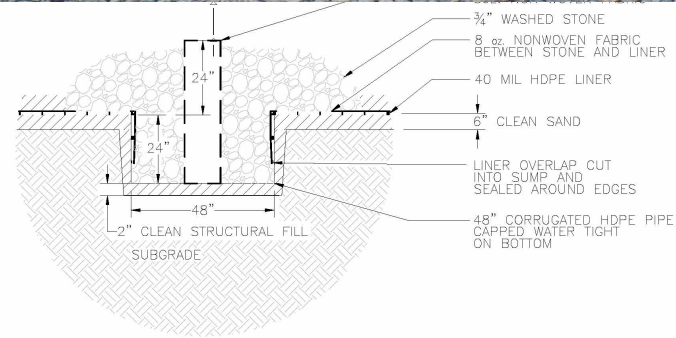
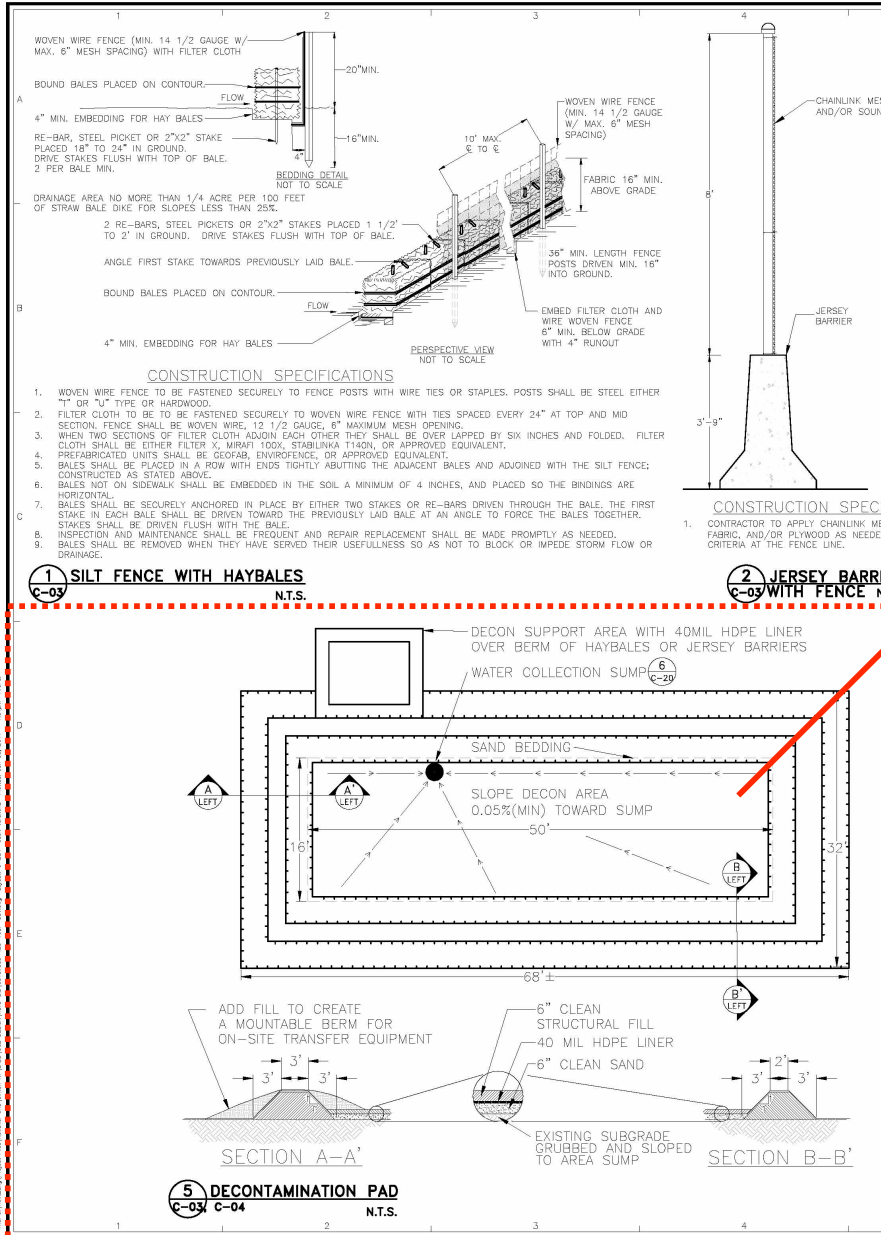

SITE PREPARATION AND EROSION CONTROL DETAILS	NATC FORM MANUFACT	PROJ. NO.: 60137
	DRAWING NUMBER:	
	C-20	
	SHEET NUMBER:	
1 OF 2		REVISOR:

# Site Control – Odor and Vapor



**FOAMING**



# Site Control - Trucks



# Site Monitoring - Treated Water

- APPROXIMATE LOCATION OF CONSTRUCTION WATER MONITORING STATION

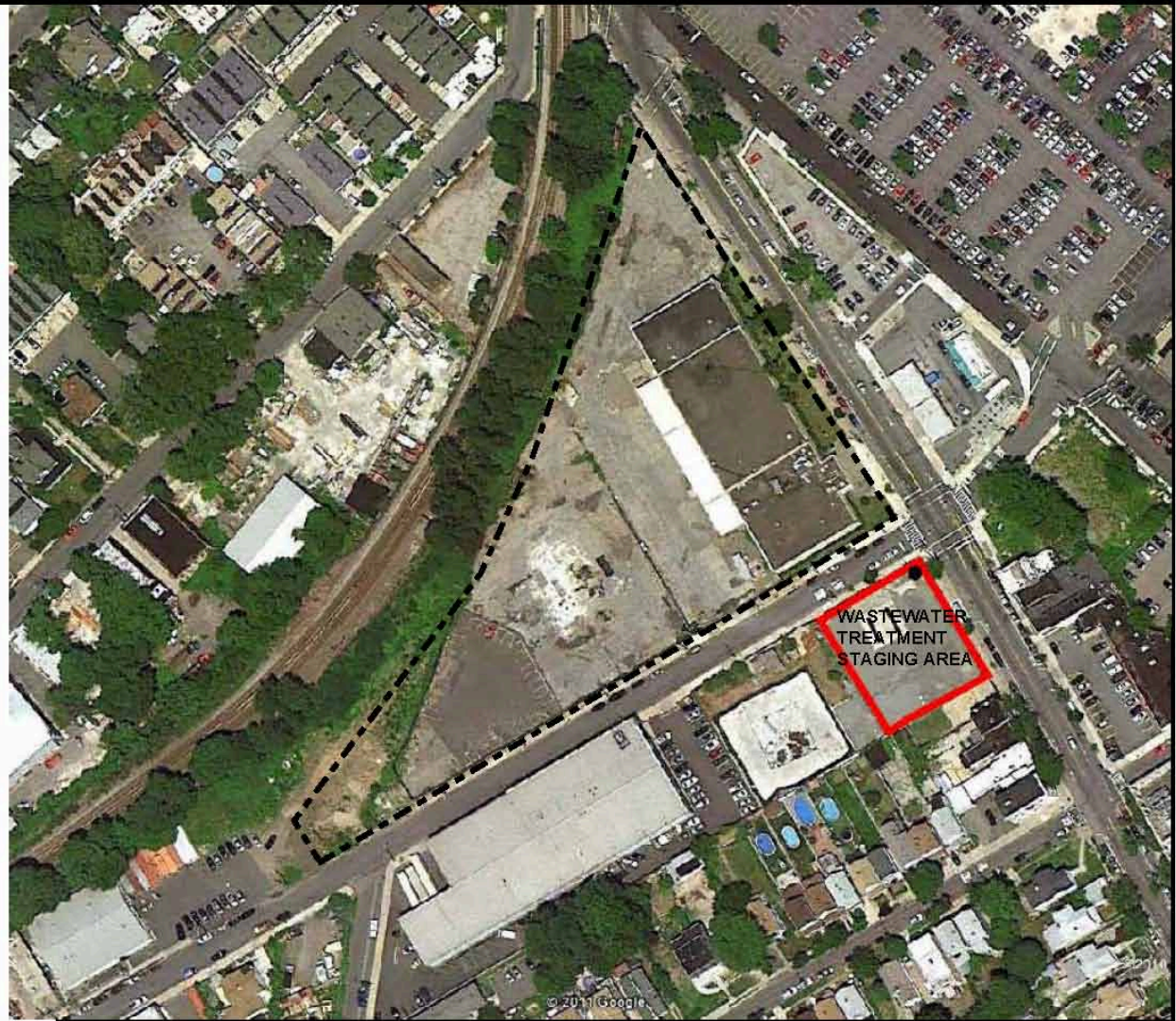

NATIONAL GRID  
FORMER MANUFACTURED GAS PLANT  
60137363-430

DATE: 12/2011

PROPOSED TREATED CONSTRUCTION WATER  
MONITORING LOCATIONS

FIGURE 1

# Offsite Monitoring - Noise



# Offsite Monitoring - Vibration

• APPROXIMATE LOCATIONS OF VIBRATION MONITORING STATION

**S1** RECEPTOR LOCATION

**S1** SETTLEMENT MONITORING LOCATION



NATIONAL GRID  
FORMER MANUFACTURED GAS PLANT  
60137363-430

PROPOSED VIBRATION AND SETTLEMENT  
MONITORING LOCATIONS

DATE: 06/2011

FIGURE 2-1